

III. Accessories

- A. Cordeck can supply ridge & valley plates, cant strips, finish strips, sump pans, end & side closures, pour stops, deck plate, rubber cell closures, screws and other accessories needed to complete the project.

SDI Member

- I. All steel deck material is manufactured by Steel Deck Institute members or manufactured in accordance to sdi.
- II. Cordeck certifies that all material will be in accordance with the SDI Cellular Deck Manual specifications.
- III. Cordeck 1.5", 3", 4.5", 6", 7.5" Cellular Roof Deck conforms to all applicable SDI Cellular Deck Manual specifications.

Installation

1. Cordeck Steel Roof Deck shall be installed by qualified and experienced workers.
2. Roof deck installation drawings shall be submitted to the project architect and engineer for approval prior to the manufacture of materials.
3. Steel roof deck shall be placed in accordance with approved erection drawings.
4. End laps shall be a nominal 2" and positioned over supports.
5. Position each deck unit on a supporting structural frame. Adjust to final position with accurately aligned side laps and ends bearing on supporting members. On joist framing, be sure the appropriate end laps occur over a top chord angle for proper anchorage.
6. When one row is placed end to end, begin another, making alignment adjustment if necessary.
7. Each deck unit shall be placed on supporting steel framework and adjusted to final positions before permanently fastened. Do not use unfastened deck as a working platform or storage area.
8. Cutting of openings through the deck and all skew cutting shall be performed in the field. Openings not shown on the erection drawings such as those required for stack, conduits, plumbing, vents, etc., shall be cut, and reinforced if necessary, in accordance with SDI.

Attachment

1. Roof deck sheets shall be attached as soon as possible after placement. All sheets placed shall be attached prior to the end of each work day. Arc welding is the most commonly used method for attaching Cordeck Steel Roof Deck to structural supports. Welder shall immediately follow the placement crew.
2. All welds are to be made from the top of the deck down through the bottom flange of the ribs. Welds shall penetrate and attach all thicknesses of material to the structural supports.
3. Caution shall be exercised on the selection of the electrodes to provide positive attachment and to prevent high amperage blow holes.
4. Puddle welds shall be at least 5/8" diameter or elongated puddle welds with an equal perimeter. Fillet welds, when used, shall be at least 1" long.
 - A. 1.5", 3", 4.5", 6", 7.5" Cellular Roof Deck ends shall be welded to structural supports at 12" on center maximum and 18" on center maximum at intermediate supports or as indicated on erection drawings.
 - B. Various mechanical fastening systems other than welding are recognized as viable anchoring methods provided that they are reviewed, approved or specified by the project designer. These include but are not limited to power-activated or pneumatically driven fasteners and screws.
 - C. When spans exceed 5'0", side laps shall be fastened together at a maximum spacing of 36 inches on center or as indicated on erection drawings.

Storage and Handling

1. Protect steel deck from corrosion, deformation, and other damage during storage, handling, and installation.
2. Deck not promptly erected shall be stored off the ground, with one end elevated to provide drainage. Bundles must be protected against condensation with a ventilated waterproof covering. Deck should always be protected from snow and salt.
3. Bundles must be stacked so there is no danger of shifting or material damage. Bundles must be checked for tightness, and retightened as necessary.
4. Deck bundles on the building frame must always be placed near a main supporting beam at a column or wall. In no case are the bundles to be placed on unbolted frames or on unattached and unbridged joists. The structural frame must be properly braced to receive the bundles.

© 2007 KAM Industries, Ltd., d/b/a Cordeck.



Toll Free: 877.857.6400
Ph: 262.857.3000
Fx: 262.857.3533
www.cordeck.com



6.0" Cellular Roof Deck

Cellular Deck brought to you by the Customer Service Leader

Cordeck is a full-service manufacturer and stocking distributor of corrugated steel deck, flashing & trim, and other building construction accessories. Cordeck's mission is to provide excellent customer service. This mission is the foundation for industry wide recognition as service leader for prompt, reliable deliveries, guaranteed quality and large inventory of gauges and profiles. Cordeck's composite cellular deck provides an ideal solution for long spans, flat acoustical ceilings, canopies and raceways. You can be certain of the product's total, maximum effectiveness, along with our ability to deliver the industry's highest quality, service, value, and customer satisfaction. Please contact us for further information. At Cordeck, we're devoted to our customers. We stand ready to earn, and keep, your full confidence and trust.

Features & Benefits

The addition of the bottom plate increases the span and load carrying capabilities allowing for **long spans**.

Prompt lead times are our speciality. All orders are promptly produced and shipped to meet your on-site specifications.

Flat ceilings offer an architectural design element offering a smooth, flat appearance.

Project management and engineering services are offered by Cordeck's full, expert, in-house engineering and detailing services to assure optimal planing and design. Our experienced engineers and technicians provide individual customer service and attention to detail from concept to completion.

AutoCAD® drawings. Can be transferred electronically via the internet or loaded onto CD for improved quality and reduced time and cost of drawing transmittal.

Bundle Placement plans ensure correct location of bundles during unloading and hoisting to steel framework.

SDI Membership by the manufacturer guarantees product quality in accordance to the Steel Deck Institute.

On-spec, guaranteed quality. Our production staff are true craftsmen, not just interested in getting the job done, but in doing it perfectly.

Knowledgeable, courteous, caring employees through out our ranks. We're a "family business"...no "big corporate" attitude here! We genuinely appreciate our customers' patronage and trust, handling every order, regardless of size, with utmost care and attention.

Acoustical roof deck is perforated designed to serve as a **sound absorption element and structural roof deck.** Typical applications for acoustical deck is in a gymnasium or pool facility. The perforation pattern is 5/32" diameter holes staggered 3/8" on center. Structural properties are negligibly affected by web perforations in fluted deck or bottom plage perforations in cellular deck (less than 5%). The sound absorbing elements consist of strips of glass fiber, that are inserted at the plant prior to delivery. Stand off clips are used to elevate the glass fiber off the deck surface.

"can do...whatever it takes"

Updated June 2007 - For latest spec visit www.cordeck.com or call 877-857-6400

6.0" Cellular Roof Deck

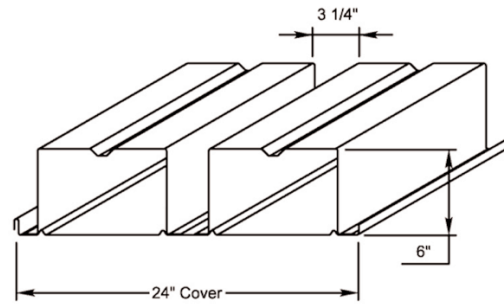

Section Properties (per ft. of width)

Gage	Design Thickness in	F _y ksi	S _p in ³	S _n in ³	I _p in ⁴	I _n in ⁴	A _s in ²	W _d psf
20-20	0.0359 / 0.0359	33	1.606	1.652	6.450	5.763	1.47	5.0
18-20	0.0478 / 0.0359	33	3.035	1.820	9.465	6.865	1.76	6.0
18-18	0.0478 / 0.0478	33	2.456	2.524	7.659	8.372	1.91	6.5
16-18	0.0598 / 0.0478	33	4.113	2.625	12.705	9.499	2.17	7.4
16-16	0.0598 / 0.0598	33	3.688	3.358	13.341	10.932	2.35	8.0

* 14 Gage Available upon request, call 877.857.6400 or 262.857.3000 for spec information.

Allowable Uniform Total Loads - psf

F_y=33 ksi

Number of Spans	Gage	Span - Feet & Inches													
		8'-0"	8'-6"	9'-0"	9'-6"	10'-0"	10'-6"	11'-0"	11'-6"	12'-0"	12'-6"	13'-0"	13'-6"	14'-0"	14'-6"
1 span	20/20	91	85	81	76	73	69	66	63	61	58	56	54	52	50
	18/20	182	171	161	153	145	138	132	126	121	116	112	108	104	100
	18/18	182	171	161	153	145	138	132	126	121	116	112	108	104	100
	16/18	302	285	269	255	242	230	220	210	202	194	186	179	173	167
	16/16	302	285	269	255	242	230	220	210	202	194	186	179	173	167
2 span	20/20	103	97	92	87	83	79	75	72	69	66	64	61	59	57
	18/20	174	164	155	147	139	133	127	121	116	111	107	103	100	96
	18/18	174	164	155	147	139	133	127	121	116	111	107	103	100	96
	16/18	258	243	230	217	207	197	188	180	172	165	159	153	148	142
	16/16	258	243	230	217	207	197	188	180	172	165	159	153	148	142
3 span	20/20	114	107	101	96	91	87	83	79	76	73	70	67	65	63
	18/20	198	186	176	167	158	151	144	138	132	127	122	117	113	109
	18/18	198	186	176	167	158	151	144	138	132	127	122	117	113	109
	16/18	293	276	261	247	235	224	213	204	196	188	181	174	168	162
	16/16	293	276	261	247	235	224	213	204	196	188	181	174	168	162

Sound Absorption Data

Panel Profile	Absorption Coefficient						NRC	Glass Fiber Roof Insulation
	125 HZ	250 HZ	500 HZ	1,000 HZ	2,000 HZ	4,000 HZ		
BW-A	0.53	0.95	1.02	0.96	0.55	0.30	0.85	1-7/8"
N-A	0.93	1.26	1.09	0.90	0.56	0.37	0.95	2"
1-1/2" Cellular-A	0.20	0.33	0.74	1.00	0.57	0.41	0.65	2"
3" Cellular-A	0.46	0.64	1.12	0.99	0.76	0.58	0.90	2"

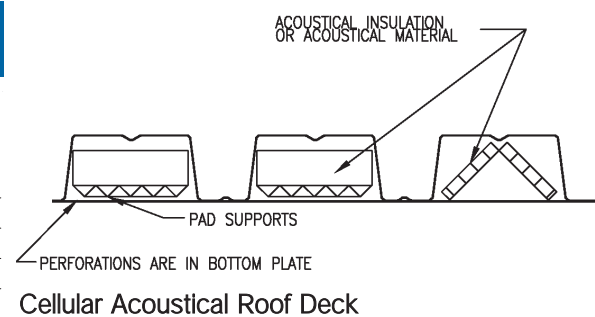

Performance values are based upon test conducted by Riverbank Acoustical Laboratories.

Acoustical tests conducted by Riverbank Acoustical Laboratories for the Steel Deck Institute with 3" EPS Plaza Deck Foam

Roof Insulation found the NRC values to be .65 for 1-1/2" WR Deck and .70 for 3" DR Deck.

The information presented in this cut sheet has been prepared in accordance with generally recognized engineering principles. We recommend that this information not be used or relied upon for any application without a thorough review and approval by a licensed professional engineer, designer or architect of the proposed application.

Product Information

Design

- I. Cordeck certifies that our 1.5", 3", 4.5", 6", 7.5" Cellular Roof Deck has been evaluated in accordance with the applicable SDI Standards and property values for the Uniform Load Tables and meets or exceeds SDI requirements.
- II. Load shown in tables is uniformly distributed total (dead plus live) load in psf (kPa). Loads in shaded areas are governed by live load deflection not in excess of L/240, the dead load included in 10 psf (0.478.kPa). All loads are governed by the allowable flexural stress limit of 20 ksi (140 Mpa) maximum yield steel. Where heavy construction loads or other unusual concentrated loads are anticipated during the lifetime of the deck, the specified live load must be increased to offset the effects of the abnormal concentrated load. See Maximum Spans for Construction and Maintenance Loads in the SDI Design Manual.
- III. The rib width limitations shown are taken at the theoretical intersection points of the flange and web projections. Depending on the radius used, the load table could vary from that shown.
- IV. Span length assumes center to center spacing of supports. Tabulated loads shall not be increased by assuming clear span dimensions.
- V. The sectional properties for Cordeck 1.5", 3", 4.5", 6", 7.5" Cellular Roof Deck have been evaluated with the latest edition of the American Iron and Steel Institute (AISI) Specification for the Design of Cold-Formed Steel Structural Members.
- VI. Bending moment formulae used for flexural stress and deflection limitations in accordance with Steel Deck Institute are:

Design	Moment	Deflection
One Span	$M = fS = \frac{w \cdot L^2}{8} \cdot 12$	$D_{max} = \frac{0.0130 \cdot w \cdot L^4}{EI} \cdot 1728$
Two Span	$M = fS = \frac{w \cdot L^2}{8} \cdot 12$	$D_{max} = \frac{0.0054 \cdot w \cdot L^4}{EI} \cdot 1728$
Three or More Spans	$M = fS = \frac{w \cdot L^2}{10} \cdot 12$	$D_{max} = \frac{0.0069 \cdot w \cdot L^4}{EI} \cdot 1728$

W = psf (kPa) L = ft. (MPa) E = 29.5 x 10⁶ psi (210,000 MPa) I = in⁴/ft. (mm⁴/m)

- Value VII. Cordeck guarantees that our 1.5", 3", 4.5", 6", 7.5" Cellular Roof Deck conforms to the Roof Deck Specifications of the Steel Deck Institute and the dimensional parameters established for the load table.

Material

- I. Certification
 - A. Steel roof deck will be 1.5", 3", 4.5", 6", 7.5" Cellular Roof Deck as manufactured by Cordeck from steel conforming to ASTM A653 for galvanized deck or ASTM A1008-00 Grade 33 for cold rolled prime painted steel. The steel used shall have a minimum yield strength of 33 KSI (230MPa)
- II. Steel Deck Finishes.
 - A. All steel to be used in 1.5", 3", 4.5", 6", 7.5" Cellular Roof Deck will be galvanized, prime painted, or a combination of the two.
 - i. Prime Painted
 1. Roof deck shall receive one coat of standard gray primer paint over cleaned and pretreated steel.
 2. The primer coat is intended to protect the steel for only a reasonably short period of exposure, in normal atmospheric conditions, and shall be considered an impermanent and provisional coating.
 3. Field painting of prime painted material is recommended especially where the deck is exposed.
 - ii. Galvanized.
 1. All steel shall be coated to conform to ASTM A924 G-60 or G-90 or to Federal Specification QQ-S-775.
 2. Galvanized finish in G-60 or G-90 coating is desirable in high moisture atmospheric conditions.
 - B. Cordeck shall not be responsible for the cleaning of the underside of steel deck to ensure bond of fireproofing. Adherence of fireproofing material is dependent on many variables. The adhesion ability of fireproofing materials is the responsibility of the fireproofing applicator.